



SEALING & BONDING SIKA PASSIVE FIRE PROTECTION SOLUTIONS

BUILDING TRUST





SIKA SOLUTIONS TAME THE ELEMENT

Fire has been a fascinating element for thousands of years and many achievements in the history of mankind were only possible with its help.

As much as controlled fire has been driving success and wealth as badly it can hurt us – when out of control – and destroy achievements of decades within minutes. Therefore it is in everybody's interest not to lose control over this powerful and elementary force.

Sika provides comprehensive solutions where fire resistant construction is required such as commercial, public and residential buildings, steel structures and others. Fire resistant sealants, fillers and backing materials for linear seals as well as solutions for penetration seals enable safer buildings and infrastructure to be built.

Our products comply with the latest relevant standards and can be used for a wide range of fire protection uses in linear seals, cavity barriers and penetration seals.

CONTENTS

05	Sika passive fire protection – solutions that may save lives and protect property
06	Reaction to fire and resistance to fire
10	Linear seals, cavity barriers and service penetration seals
15	Intumescence and intumescent materials
16	Linear seals, field of application
17	Pipe end-configurations
18	Flexible walls and rigid walls
19	Classification of linear seals
20	Sika passive fire protection – typical applications
22	Sika passive fire protection – a full product range
24	Sikasil®-670 Fire
25	Sikacryl®-621 Fire
27	Sikacryl®-620 Fire
28	Sika® Backer Rod Fire
29	Sikaflex®-400 Fire
30	Sika Boom®-400 Fire
32	SikaSeal®-623 Fire
33	Sikacryl®-624 Fire
34	Sikacryl®-625 Fire
35	SikaSeal®-626 Fire Board
36	SikaSeal®-627 Fire Collar
37	Sikacrete®-630 Fire
38	SikaSeal®-628 Fire Wrap
39	SikaSeal®-629 Fire Wrap
40	Sika as a solution provider
41	SikaCem® Pyrocoat
42	EMSEAL Emshield WFR
43	EMSEAL Emshield DFR
44	Fire protective coatings for load bearing structures
48	Fire protective systems for steel structures
52	Fire protective systems for wood
53	Fire protective systems for concrete





SIKA PASSIVE FIRE PROTECTION

Solutions that may save lives and protect property

Urbanisation – a much-debated megatrend – can be considered one of the key drivers of why passive fire protection is an increasingly important part of today's building industry: The more concentrated conditions and environments that we live in, the higher the risk of a life-threatening fire. Consistent use of integrated and effective passive fire protection is the most effective way to minimize this risk and protect people's life, their property and the environment.

Modern building frameworks are interspersed with multiple utility and network services including cables, pipes and ventilation ducts in both horizontal and vertical directions, resulting in countless penetrations through most of the walls and floors. Each of these penetrations and every joint between different building structures, elements and areas, is potentially a passage for the spread of flames, heat and toxic smoke into adjoining rooms and areas, which – in the worst case – may result in uncontrolled fire propagation throughout the entire building. This is where fire protection comes into play: Whilst active fire protection systems such as sprinklers, can

extinguish fires, **passive fire protection** is designed to prevent the spread of fire and contain it in defined compartments to minimize damage and – even more importantly – to allow people in other compartments time to evacuate safely. In the event of a fire, the heat and smoke will spread through penetrations and joints in the walls and floors, causing damage, endangering people and potentially also blocking escape routes.

Sika's passive fire protection solutions are designed to be able to seal all different types of building joints and penetrations, in order to help keep fire in defined compartments for a certain period of time, thereby allowing people to evacuate safely.

Sika passive fire protection solutions comply with the most relevant national and international standards (including EN, UL, EAD (ETAG), ASTM, AS, Certifire), in order to confirm that they meet the highest fire resistance requirements and consequently can help save people's lives!



REACTION TO FIRE AND RESISTANCE TO FIRE

Fire resistance testing can be a very complex topic – the differences between ‘reaction to fire’ and ‘resistance to fire’ can frequently cause some confusion, but can be clarified as follows:

Reaction to fire describes how a material contributes to the development and spread of a fire. Typically reaction to fire is

determined for a single material or product such as a wall covering or joint sealant, and not for a system or section such as a wall including the linear joints and any penetrations. In Europe reaction to fire is now classified according to European Standard EN 13501-1, which is gradually replacing older national standards such as the German DIN 4102.

Euro class	Requirement	Examples of materials
A1	No contribution to fire	Stone, concrete, glass, most metals
A2	Insignificant contribution to fire	Similar to A1 including small amounts of organic compounds
B	No spread of fire and very limited contribution to fire	Gypsum boards with very thin surface covering, fire rated sealants
C	Very limited spread of fire	Gypsum boards with thicker surface coverings
D	Limited spread of fire	Wood & wooden products (depending on size)
E	Acceptable reaction to fire in case of a very small flame	Many plastic products and materials
F	Not passing requirements for classes A1-E	Other materials than classes A1-E





REACTION TO FIRE AND RESISTANCE TO FIRE

Resistance to fire describes the ability of a building element to prevent the passage of heat and flames from one side to another. Typically such building elements are walls or floors including any joints and penetrations, windows and doors etc. This means that not only a specific material or product, but an entire system or building section has to be tested. There are many different national and international test standards and classification schemes for fire resistance, however most of them follow the same principle: The building element or component for testing, including all of the service penetrations, joints, doors, windows and the joint sealant in and around them, is fixed into a test frame which is then attached to a test furnace. The side facing towards the furnace is known as the exposed or fire side, whilst the outer side is the unexposed or non-fire side. The furnace temperature is raised according to a defined curve reaching 945°C after 60 minutes and 1'153°C after 240 minutes. Two parameters are relevant for most fire resistance tests: Integrity and Insulation.

E – Integrity

Integrity (E) is a building element's capability – when exposed to fire on one side – to prevent the passage of flames and hot gases to the unexposed side.



I – Insulation

Insulation (I) is a building element's capability to maintain its thermal insulation function when exposed to fire on one side. Most standards allow a maximum of 180°C temperature rise on the unexposed side.



Standard	Description, Scope	Remark
EN 1366-3	Test standard for penetration seals	Most relevant standards for resistance to fire testing.
EN 1366-4	Test standard for linear joint seals	Also referred to in EAD and partly AS 1530.4
EN 13501-2	Classification standard for linear joint seals and service penetration seals	Leading to EI classes. Relevant for EN 1366 and EAD
BS 476-20	Test standard for linear joint seals and service penetration seals	British standard; superseded by EN 1366/EN 13501 but still used in some regions
EAD 350454-00-1104	Fire stopping and fire sealing products – penetration seals	Superseded ETAG 026. Leading to CE marking and DoP. Fire resistance tested acc. EN 1366
EAD 350141-00-1106	Fire stopping and fire sealing products – linear joints and gap seals	
UL	Certification scheme for product safety based in the US	Different test methods and requirements for different regions (e.g. UL EU and UL US/UL C)
AS 1530.4	Test and classification for linear joint seals and service penetrations	Australian standard, technically very similar to EN 1366
Certifire	Certification scheme for fire protection products	Relevant in the Middle East

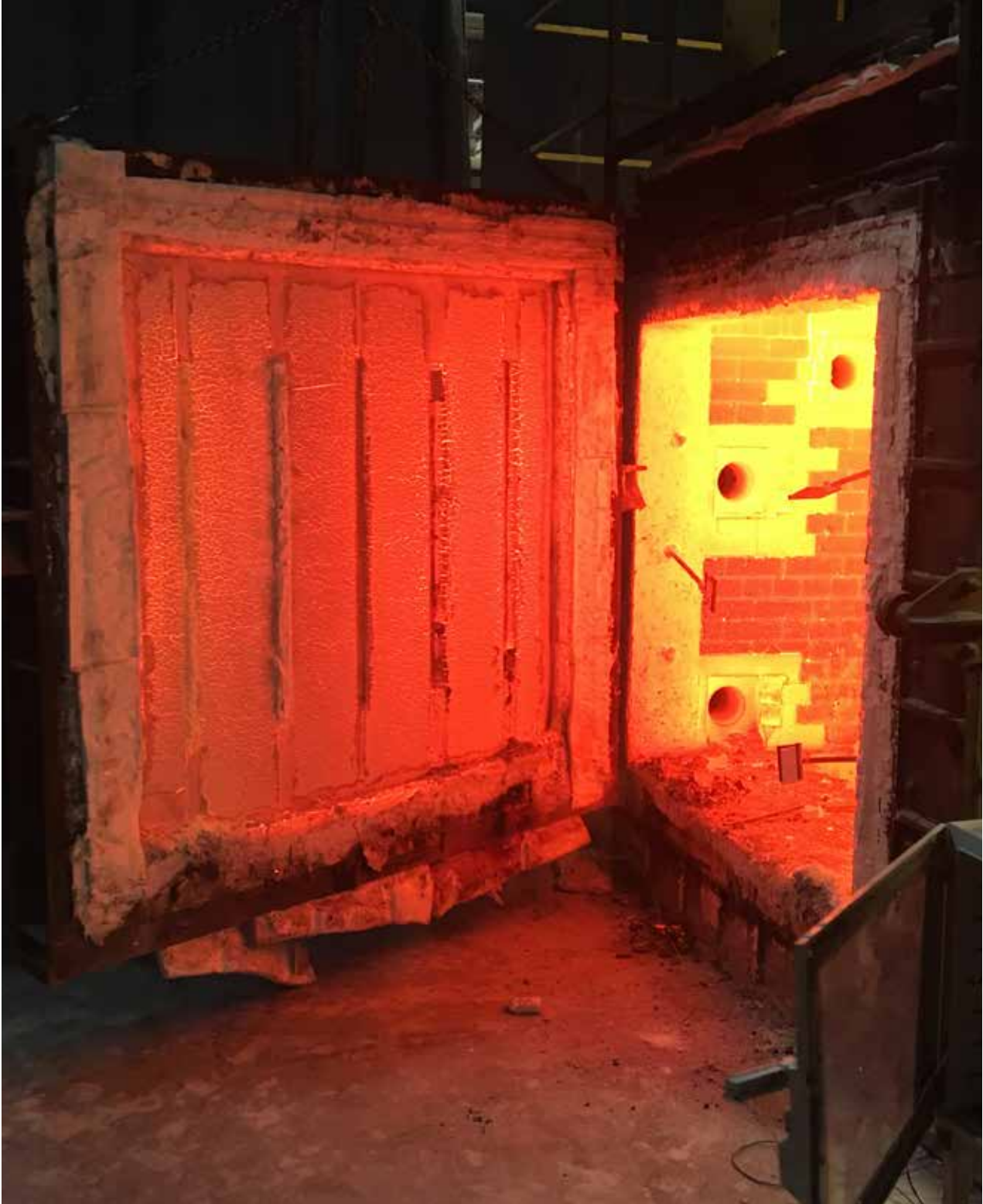

Furnace with vertical linear seals after resistance to fire test acc. EN 1366-4

LINEAR SEALS, CAVITY BARRIERS AND SERVICE PENETRATION SEALS

Passive fire protection applications for compartmentations can be divided into the following three main groups:

- Linear joint seals
- Cavity barriers
- Penetration seals

Linear joint seals are passive fire protection systems designed to maintain the required building fire resistance across a separating element plus, if and where relevant, to accommodate a defined degree of movement. Linear joint seals can be found in walls, floors and in so called head of wall applications – joints between wall and ceiling or wall and floor.

A fire resistant linear joint seal can be achieved by different approaches:

- The most common way is to use a fire-resistant joint sealant in combination with a standard PE backing rod. In this case only the sealant is usually required to provide fire resistance while the backer rod is considered as sacrificial.
- An alternative approach is to use a fire-resistant backer rod – typically based on an inorganic fire resistant material like mineral wool – and combine it with a standard joint sealant. In this case the fire resistance of the linear seal is provided by the backer rod and the joint sealant is used to accommodate limited movement, ensure water tightness and provide mechanical protection.
- The 3rd option is to seal the joint with a fire-resistant expanding foam. This system is only recommended where the joints have very limited movement and are not exposed to water, UV radiation or mechanical impact.



PE backer rod and fire resistant sealant



Fire resistant backer rod and standard joint sealant



Fire resistant expansion foam



The following parameters have an influence on the fire resistance of a building element and hence of its classification. Therefore it is crucial to know all relevant details to select the right product.

- 1** Types of involved building material
e.g. concrete/steel
- 2** Element orientation horizontal (floor)
or vertical (wall)
- 3** Element thickness
- 4** Joint dimension (width, depth)
- 5** Joint configuration: Single seal exposed/
unexposed, double seal
- 6** Expected joint movement



LINEAR SEALS, CAVITY BARRIERS AND SERVICE PENETRATION SEALS

Cavity barriers are passive fire protection systems similar to linear (floor-) seals but wider than standard joints in most cases. Cavity barriers typically can be found between floor slabs and curtain wall facades or in wide gaps within a building.

Such cavity barriers are designed to avoid the spread of fire from one floor to the other which is one of the major threats when highrise buildings catch fire.

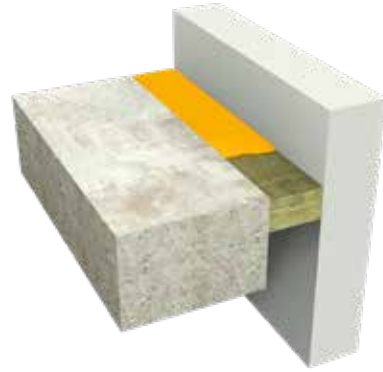

Service penetration seals are passive fire protection systems designed to maintain the fire resistance of a building element or section – wall or floor – where services such as cables, cable trays, pipes or ventilation ducts pass through them.

The vast number of different building materials and different services and the types of penetrations that can be required, leads to a wide variety of different solutions for sealing around these service penetrations. The result is that for most of these penetration sealing applications, several alternative solutions, with different systems and products can be used – if the combination has been tested.

One of the challenges with sealing around penetrations is that certain services (e.g. combustible pipes) will melt in the event of a fire, which results in even larger apertures that must be closed immediately. For this type of application, expanding intumescent materials are usually a very effective solution.





INTUMESCENCE AND INTUMESCENT MATERIALS

Many passive fire protection products are claimed to be intumescent – what does this mean and when can a product be classed as intumescent?

An intumescent is a substance that swells as a result of heat exposure, thus increasing in volume and decreasing in density. Intumescent materials used in fire protection will increase their volume significantly under the influence of heat (typically at 300°C – 500°C). This physical process is one of the main principles for passive fire protection products: Intumescent sealants are able to close gaps in and around service penetration seals very quickly in the event that a fire occurs.

These are particularly useful for sealing around any combustible service pipes – which can melt and create larger openings in the building floors and walls – an important role in passive fire protection. However, not all passive fire protection products are intumescent; for instance flexible silicone joint sealants, acrylic sealants and some coated insulation boards are used for passive fire protection based on different chemical and/or physical principles.

Unfortunately at this time there is no clear definition of how much a material or product has to expand under heat in order to be classed as intumescent. This means that building owners and their professional construction team must take steps to check and confirm that the intumescent materials, systems and products selected and used, will perform and that their volume will expand sufficiently to seal the dimensions of any openings and gaps that could be created during a fire.

Cautionary note: there are some products on the market with less than a 30% volume increase, which are being marketed as being intumescent – Buyer beware!

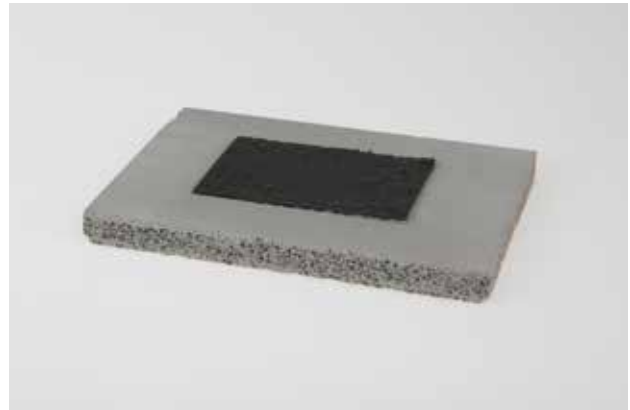

Highly intumescent, fire resistance wrap before (top) and after (bottom) exposure to heat

LINEAR SEALS, FIELD OF APPLICATION

EN 13501-2 defines in which situations a tested linear seal orientation can be applied to other orientations in practical use. The tables below show a simplified version of these definitions. In practice this means that vertical joints in walls (B) and horizontal joints in walls (C) are only covered if this specific orientation has been tested, whilst joints between ceilings and walls (D, known as heads of walls) are covered by the testing of seals for joints in floors (A).

A	Linear joint in a horizontal test arrangement (floor)
B	Vertical linear joint in a vertical test arrangement (wall)
C	Horizontal linear joint in a vertical test arrangement (wall)
D	Horizontal wall joint abutting a floor, ceiling or roof (head of wall)

Tested orientation	Covered application(s)
A	A, D
B	B
C	C

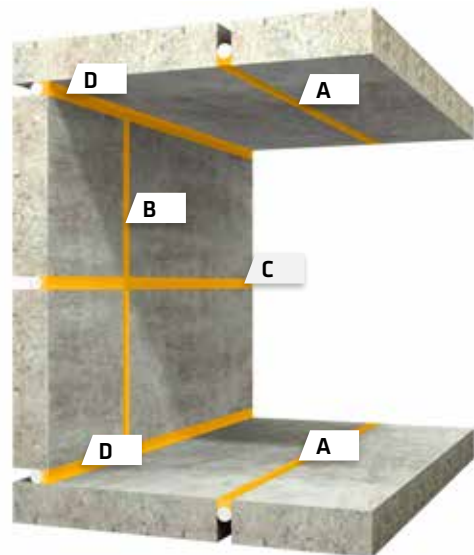

PIPE END-CONFIGURATIONS

The pipe end-configuration for fire protection describes whether the ends of a pipe are closed or open (C for capped and U for uncapped). EN 1366-3 defines 4 possible pipe end configurations considering that each pipe has two ends, one on its exposed side (in the furnace) and one on its unexposed side (outside the furnace). The pipe end configuration has a significant influence on the heat flux during a fire and hence on the fire resistance rating of the penetration seal under test. The table below shows that the testing of a defined configuration also covers other less severe configurations in similar applications.

Tested configuration	Covered configurations
U/U	U/U, C/U, U/C, C/C
C/U	C/U, U/C, C/C
U/C	U/C, C/C
C/C	C/C

The first letter represents the end of the pipe on the exposed end while the second letter stands for the unexposed end of the pipe. For example a pipe classified as U/C indicates that the pipe was tested uncapped in the furnace and capped outside the furnace.

An capped pipe end does not necessarily mean that this pipe ends in a compartment or room with a capping, but in most cases it will continue to another compartment, or leave the building again without opening. Soil and vent pipes for example are generally uncapped at the drainage end and capped (not having any opening) until they leave the building. Closed circuits like gas supply pipes, compressed air or similar are also uncapped at both ends.



FLEXIBLE WALLS AND RIGID WALLS

In principle each type of structural element (walls or floors) will lead to a different fire resistance classification and consequently these have to be tested separately. For simplification EN 1363-1 defines two generic classes of walls; testing using one of these will cover a wider range of substrates than just the one tested. Thanks to this rule resources can be saved without compromising on safety.

- Flexible wall substrates are lightweight gypsumboard faced steel or timber stud wall partitions made from defined materials and dimensions.
- Rigid wall substrates consist of aerated concrete blocks produced with a consistent density of approx. 650 kg/m^3 .

Tests performed with these flexible wall substrates are suitable to cover all flexible walls of the same composition and the same or higher thickness, as well as rigid walls of the same or higher thickness. Tests performed on the rigid wall substrates are suitable to cover all rigid walls of the tested or higher thicknesses and of the tested or higher material densities (e.g. precast concrete instead of aerated concrete).



Flexible wall (left) and rigid wall (right) systems with service penetrations and seals



CLASSIFICATION OF LINEAR SEALS

EN 13501-2 is the European classification standard for fire resistance of many building elements including linear seals and penetrations. The classification for linear seals provides information on 5

variable parameters, some of which are well known, whilst others are used less frequently. The following chart gives an overview of this linear seal classification system including all of the available options.

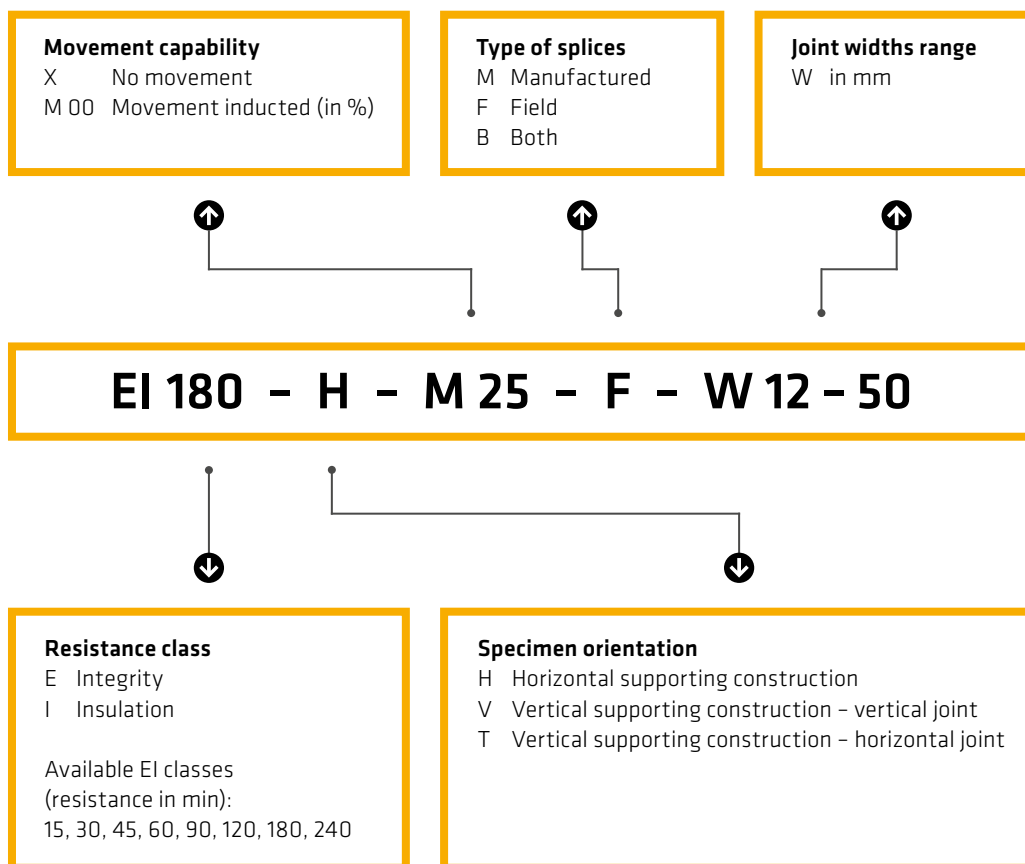

You may be asked the question: “Is your fire resistant joint seal able to accommodate movement?” Be careful! – It is not enough to use an elastic joint sealant with the required movement capability (e.g. according to ISO 11600 or ASTM C 920); because also specific fire resistance tests (e.g. according to EN 1366-4) must be performed under forced movement.

To do so the joint width is mechanically increased by the required amount (e.g. 25%) before the fire resistance test, then kept at this position for the duration of the test. From the respective product’s EN 13501-2 classification you can see what degree of movement a product was tested with:

EI 120 - V - X - F - W 0-30

Joint classification without movement (X)

EI 120 - V - M 25 - F - W 0-30

Joint classification with 25% movement (M 25)

According to EAD 350141-00-1106 (formerly known as ETAG 026) linear joint seals tested without movement can accommodate a maximum of 7.5% movement, for such joints and joint sealants the term non-movement joints is used. Internal non-structural wall and floor jointing applications (e.g. construction, connection, daywork and isolation joints) typically do not call for more than of 7.5% movement capability.

SIKA PASSIVE FIRE PROTECTION

Typical applications



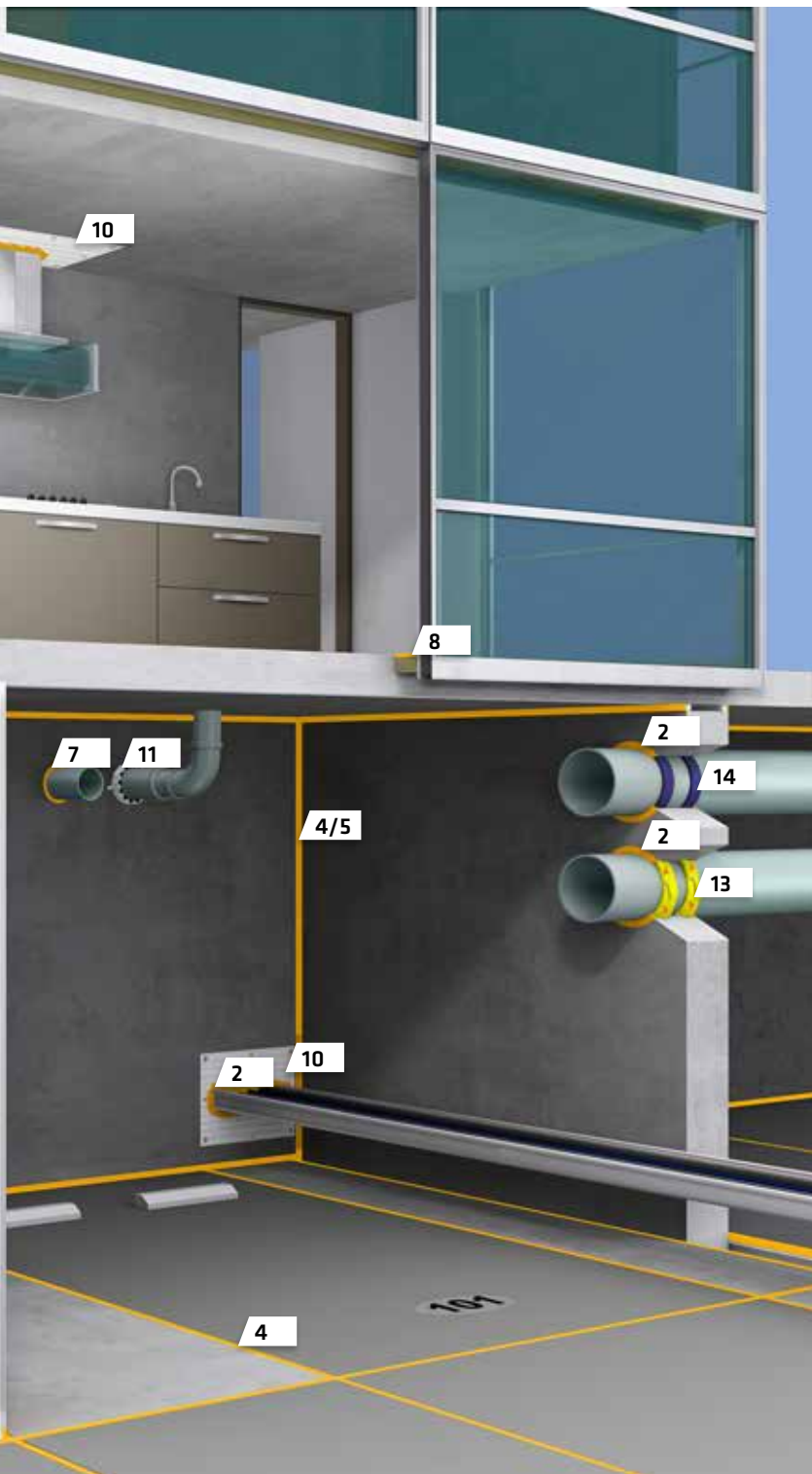

1

Sikasil®-670 Fire

Fire resistant silicone sealant for linear seals in walls and floors

8

Sikacryl®-624 Fire

Fire resistant acrylic sealant/coating for floor and wall intersections

2

Sikacryl®-621 Fire

Fire resistant acrylic sealant for service penetration and joint seals

9

Sikacryl®-625 Fire

Fire resistant ablative coating for SikaSeal®-626 Fire Board

3

Sikacryl®-620 Fire

Fire resistant acrylic sealant for linear seals and penetrations

10

SikaSeal®-626 Fire Board

Fire resistant coated protection board

4

Sika® Backer Rod Fire

Fire resistant mineral wool based backer rod system for linear seals

11

SikaSeal®-627 Fire Collar

Fire resistant pipe collar

5

Sikaflex®-400 Fire

Fire resistant PU sealant for linear seals and penetrations

12

Sikacrete®-630 Fire

Fire resistant load bearing compound

6

Sika Boom®-400 Fire

Fire resistant expansion foam for linear seals

13

SikaSeal®-628 Fire Wrap

Fire resistant pipe wrap

7

SikaSeal®-623 Fire

Fire resistant intumescent sealant for penetration seals

14

SikaSeal®-629 Fire Wrap

Fire resistant pipe wrap on a roll

SIKA PASSIVE FIRE PROTECTION

A full product range

1

Sikasil®-670 Fire

Fire resistant silicone sealant for linear seals in walls and floors

2

Sikacryl®-621 Fire

Fire resistant acrylic sealant for service penetration and joint seals

3

Sikacryl®-620 Fire

Fire resistant acrylic sealant for linear seals and penetrations

4

Sika® Backer R

Fire resistant neoprene backer rod system



Mineral Wool Board Fire
Mineral wool based
system for linear seals

5
Sikaflex®-400 Fire
Fire resistant PU sealant for linear
seals and penetrations

6
Sika Boom®-400 Fire
Fire resistant expansion foam for
linear seals

7
SikaSeal®-623 Fire
Fire resistant intumescent
sealant for penetration seals

8
Sikacryl®-624 Fire
Fire resistant acrylic seal-
ant/coating for floor and
wall intersections

9
Sikacryl®-625 Fire
Fire resistant ablative coat-
ing for SikaSeal®-626 Fire
Board

10
SikaSeal®-626 Fire Board
Fire resistant coated pro-
tection board

11
SikaSeal®-627 Fire Collar
Fire resistant pipe collar

12
Sikacrete®-630 Fire
Fire resistant load bearing
compound

13
SikaSeal®-628 Fire Wrap
Fire resistant pipe wrap

14
SikaSeal®-629 Fire Wrap
Fire resistant pipe wrap on
a roll

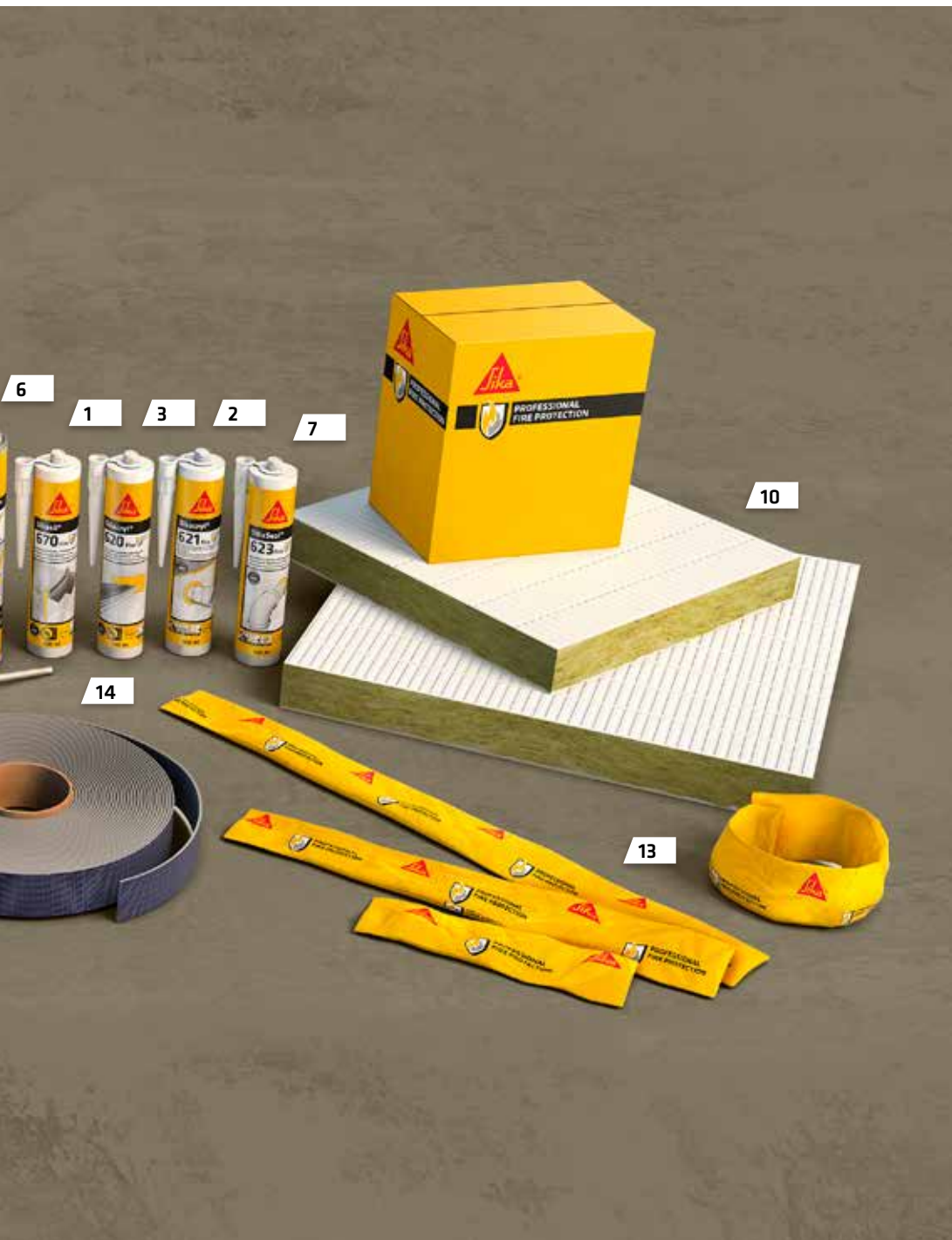

Sikasil®-670 Fire

Fire resistant silicone sealant for linear seals in walls and floors



Description

Sikasil®-670 Fire is a fire resistant, elastic, neutral curing silicone sealant for interior and exterior joints in walls and floors.

Uses

- Movement and connections joints in fire compartments like stair cases, corridors etc. (walls, floors and head to wall)
- Connections between concrete and steel elements
- Connections between concrete and wooden elements

Advantages

- Fire resistance tests under 25% movement
- Tested and classified according to many different fire resistance standards
- Up to 4 hours fire resistance
- Good adhesion to most substrates
- Neutral curing
- 1-part, ready to use

Approvals, Certificates

- ETA acc. EAD-350141-00-1106
- EN 1366-4
- EN 13501-2
- BS 476-20
- UL EU
- UL 2079
- Certifire
- EN 10140-2
- EN 15651-1, -4
- ISO 11600 F 25 LM
- ASTM C 920 class 25

Packaging

- Cartridges 300 ml, 12 pc/box
- Foil packs 600 ml, 12 pc/box

Colors

- Concrete grey
- Grey
- White
- Black

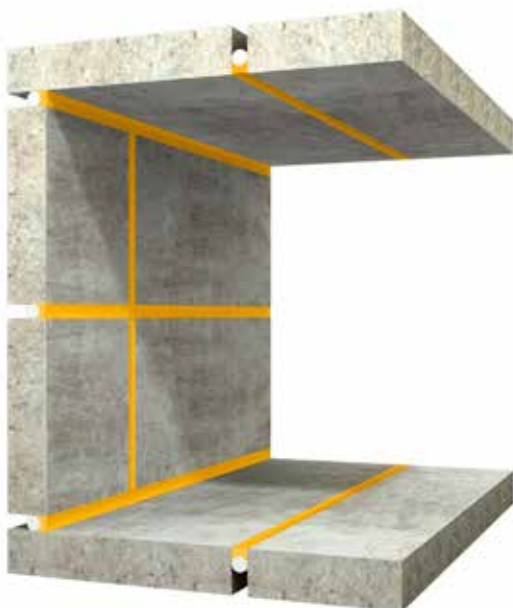
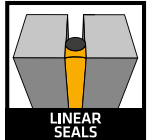

Sikacryl®-621 Fire

Fire resistant acrylic sealant for service penetration and joint seals



Description

Sikacryl®-621 Fire is a fire resistant, phthalate-free acrylic sealant for interior joints and penetration seals in walls and floors.

Uses

- Restores the fire resistance performance of a floor or wall which incorporates penetration services or linear seals
- Can be combined with SikaSeal®-626 Fire Board, SikaSeal®-627 Fire Collar, SikaSeal®-628 Fire Wrap and SikaSeal®-629 Fire Wrap.

Advantages

- Extremely versatile, can be combined with many other Sika passive fire protection products
- Provides acoustic insulation
- 1-part ready to use, easy to apply, easy to clean
- Up to 4 hours fire resistance

Approvals, Certificates

- ETA acc. EAD-350141-00-1106
- ETA acc. EAD-350454-00-1104
- EN 1366-4, EN 1366-3
- EN 13501-2
- UL EU
- Certifire
- EN 10140-2
- EN 15651-1
- Emicode EC1 Plus
- LEED Attestation

Packaging

- Cartridges 300 ml, 12 pc/box
- Foil packs 600 ml, 12 pc/box

Colors

- White
- Grey

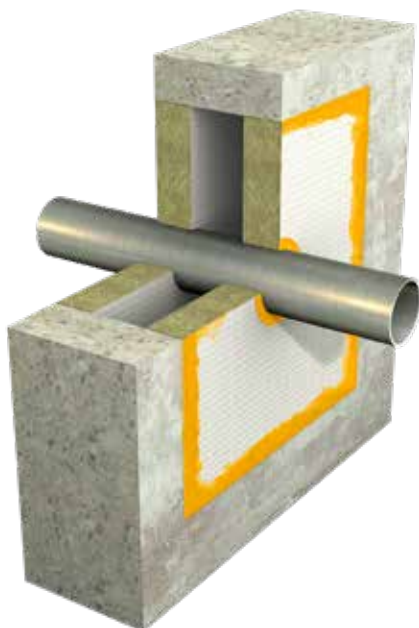
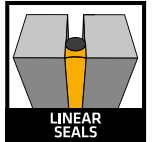



Sikacryl®-620 Fire

Fire resistant acrylic sealant for linear seals and penetrations



Description

Sikacryl®-620 Fire is a fire resistant, acrylic sealant for interior joints in walls and floors as well as penetration seals in walls.

Uses

- Connection joints in fire compartments like stair cases (walls, floors and head to wall)
- Penetration seals in flexible and rigid fire compartment walls
- Connections between concrete and steel elements
- Connections between concrete and wood elements

Advantages

- Tested and classified according to many different fire resistance standards
- Ready to use, easy to apply, easy to clean
- Up to 4 hours fire resistance

Approvals, Certificates

- ETA acc. ETAG 026
- EN 1366-4
- EN 1366-3
- EN 13501-2
- BS 476-20
- UL 2079
- Certifire
- EN 10140-2
- EN 15651-1

Packaging

- Cartridges 300 ml, 12 pc/box
- Foil packs 600 ml, 12 pc/box

Colors

- White
- Grey

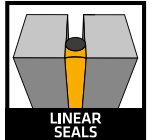

Sika® Backer Rod Fire

Fire resistant mineral wool based backer rod system for linear seals



Description

Sika® Backer Rod Fire is a fire resistant, mineral wool based backer rod for interior and exterior joints in walls and floors. Sika® Backer Rod Fire is used in combination with SikaHyflex®-250 Facade, Sikaflex® AT Connection or Sikaflex® PRO-3.

Uses

- Linear seals in fire compartments like stair cases, industrial facilities, warehouses, etc.
- Fire resistant joints exposed to chemicals or mechanical impact (in combination with Sikaflex® PRO-3).

Advantages

- Very versatile, can be combined with 3 joint sealants
- Adapts all irregularities of the joint
- Up to 4 hours fire resistance
- Efficient application from rolls

Approvals, Certificates

- ETA acc. EAD-350141-00-1106
- EN 1366-4
- EN 13501-2
- UL EU

Packaging

- 7 different diameters on rolls
- 25 - 50 m per roll, depending on diameter

Colors

- Green

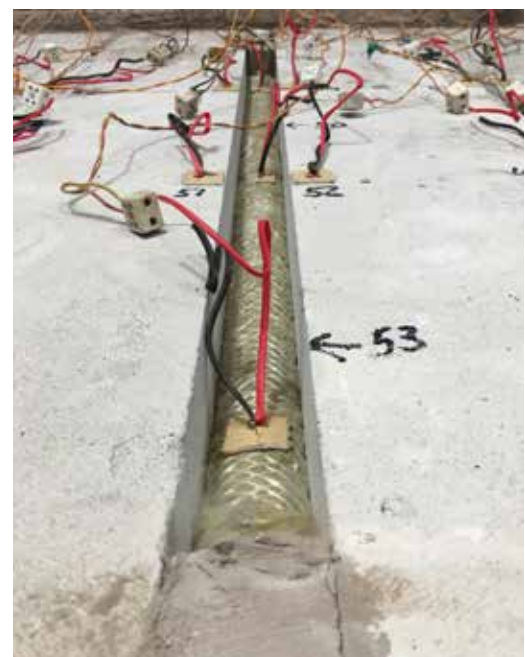
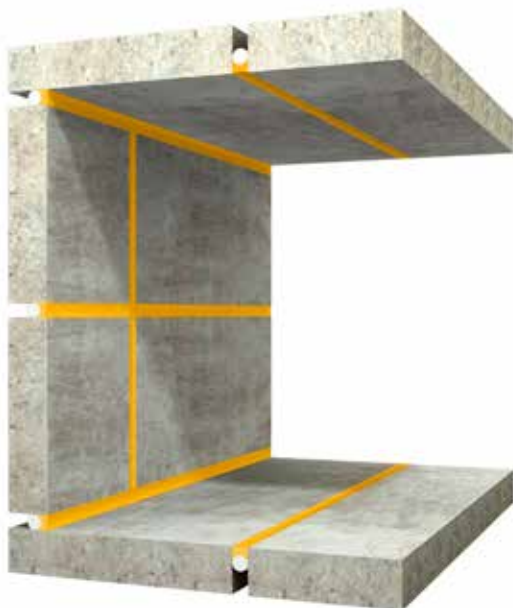
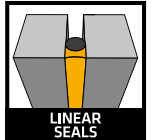

Sikaflex®-400 Fire

Fire resistant pu sealant for linear seals and penetrations



Description

Sikaflex®-400 Fire is a fire resistant, elastic sealant for interior and exterior joints in walls and floors as well as penetration seals in walls.

Uses

- Movement and connections joints in fire compartments like stair cases, corridors etc. (walls, floors and head to wall)
- Penetration seals in rigid fire compartment walls

Advantages

- Can be used for fire resistant joints and standard building joints
- Provides acoustic insulation

Approvals, Certificates

- AS 1540.3
- EN 1366-4
- EN 13501-2
- ASTM C920 class 35
- EN 15651-1
- ISO 11600
- AS 1191, ISO 10140-1
- LEED Attestation

Packaging

- Foil packs 600 ml, 12 pc/box

Colors

- Concrete grey



Sika Boom[®]-400 Fire

Fire resistant expansion foam for linear seals



Description

Sika Boom[®]-400 Fire is a fire resistant 1-part PU expansion foam for interior joints in walls.

Uses

- Joints in fire compartment walls

Advantages

- Very easy to use, fast application
- Can be used with straw or application gun
- Up to 4 hours fire resistance

Approvals, Certificates

- EN 13501-2
- EN 1366-4

Packaging

- Cans 750 ml, 12 pc/box

Colors

Pink

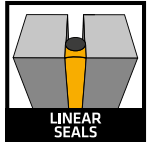



SikaSeal®-623 Fire

Fire resistant intumescent sealant for penetration seals



Description

SikaSeal®-623 Fire is a fire resistant, intumescent graphite based sealant for interior penetration seals.

SikaSeal®-623 Fire is designed to provide a high volume expansion and pressure seal during a fire to combustible pipes that pass through floor and wall service openings.

Uses

Restores the fire resistance performance of a floor or wall which incorporates combustible services like soil and vent pipes or cables

Advantages

- Highly intumescent - volume expansion 20 times original size
- 1-part ready to use, easy to apply, easy to clean
- Provides acoustic insulation
- Up to 4 hours fire resistance

Approvals, Certificates

- ETA acc. EAD-350454-00-1104
- EN 1366-3
- EN 13501-2
- UL EU
- Certifire
- Emicode EC1 Plus
- LEED Attestation

Packaging

- Cartridges 300 ml, 12 pc/box
- Foil packs 600 ml, 12 pc/box

Colors

- Anthracite

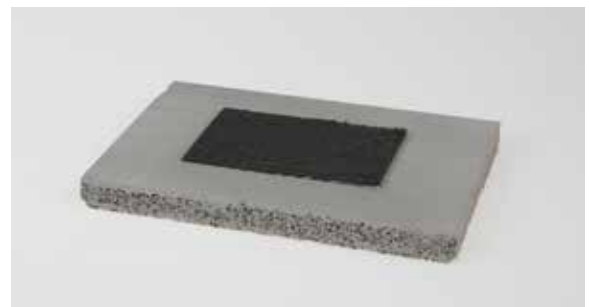

Sikacryl[®]-624 Fire

Fire resistant acrylic sealant/coating for floor and wall intersections



Description

Sikacryl[®]-624 Fire is a 1-part, fire resistant, acrylic sealant/coating for large joints in floors and floor/wall intersections in combination with mineral wool backing.

Uses

Restores the fire resistance performance of cavity barriers and joints at floor and wall intersections

Advantages

- Can be poured, spray- or brush-applied
- Provides acoustic insulation when used in combination with mineral wool
- Up to 3 hours fire resistance

Approvals, Certificates

- ETA acc. EAD-350141-00-1106
- EN 1366-4
- EN 13501-2
- UL EU
- Certifire

Packaging

- Pail with 20 kg

Colors

- White

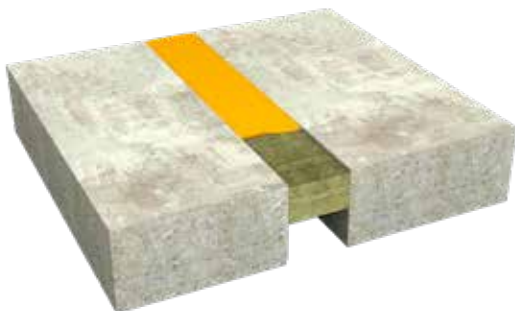
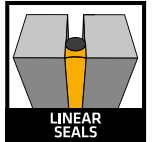

Sikacryl®-625 Fire

Fire resistant ablative coating for SikaSeal®-626 Fire Board



Description

Sikacryl®-625 Fire is a fire resistant, ablative acrylic coating used in combination with SikaSeal®-626 Fire Board.

Uses

- Edge coating of SikaSeal®-626 Fire Board when installed on the outer face of a wall or floor
- Touching up SikaSeal®-626 Fire Board after installation

Advantages

- 1-part ready to use, easy to apply, easy to clean
- Provides a neat finish on the cut edges of SikaSeal®-626 Fire Board

Packaging

- Pail with 5 kg

Colors

- White

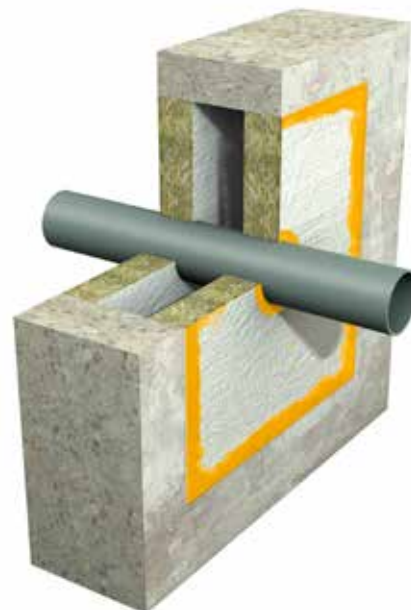
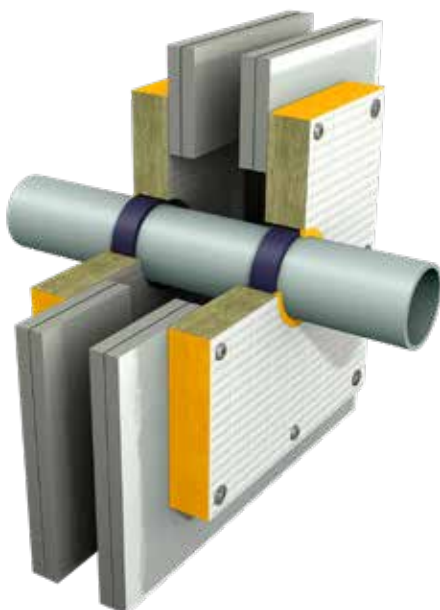

SikaSeal®-626 Fire Board

Fire resistant coated protection board



Description

SikaSeal®-626 Fire Board is a mineral wool based protection board coated with the fire resistant, ablative coating Sikacryl®-625 Fire on both sides. It is extremely versatile and can be combined with many other Sika passive fire protection products for sealing a wide range of service penetrations.

Uses

- Restores the fire resistance performance of a floor or wall which incorporates single and multiple penetration services
- Can be combined with Sikacryl®-621 Fire, SikaSeal®-623 Fire, Sikacryl®-625 Fire, SikaSeal®-627 Fire Collar, SikaSeal®-628 Fire Wrap and SikaSeal®-629 Fire Wrap.

Advantages

- For face fit (pattress-fit) and internal-fit installations
- Can be used for penetrations up to 1'200 x 730 mm
- Provides acoustic insulation

- Easy to install, no need for specialist tools
- Up to 4 hours fire resistance

Approvals, Certificates

- ETA acc. EAD-350454-00-1104
- EN 1366-3
- EN 13501-2
- UL EU
- Certifire

Packaging

- 1'200 x 600 x 50 mm, 30 boards per pallet

Colors

- White coating
- Green core

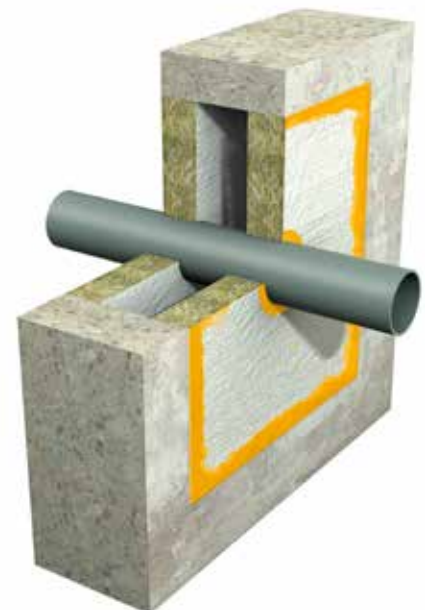
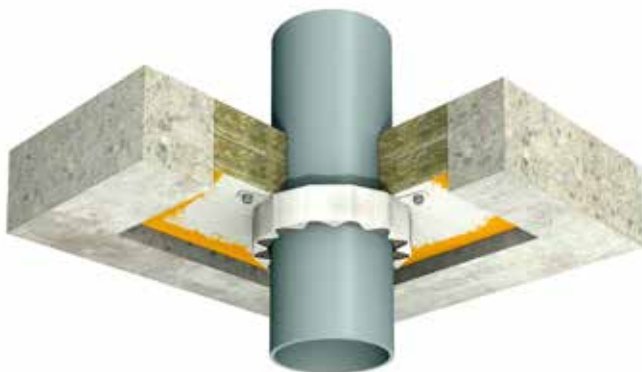

SikaSeal®-627 Fire Collar

Fire resistant pipe collar



Description

SikaSeal®-627 Fire Collar is a fire resistant prefabricated pipe collar consisting of a metal casing and an intumescent insert for interior and exterior penetration sealing applications.

SikaSeal®-627 Fire Collar is designed to provide a high volume expansion and pressure seal during a fire to combustible pipes that pass through floor and wall service openings.

Uses

- Restores the fire resistance performance of a floor or wall which incorporates service openings containing metallic, plastic or composite pipes, conduits or other services
- Outer face wall or floor application in combination with Sikacryl-621® Fire
- Can be combined with SikaSeal®-626 Fire Board and Sikacrete®-630 Fire

Advantages

- Pipe diameter range 32 – 250 mm

- Highly intumescent - volume expansion 20 times original size
- Flexible design enables installation in confined spaces
- Easy to apply - 1 part, 3 fixings for all sizes
- Up to 4 hours fire resistance

Approvals, Certificates

- ETA acc. EAD-350454-00-1104
- EN 1366-3
- EN 13501-2
- UL EU
- Certifire

Packaging

- 2 pieces per box

Colors

- White metal casing, anthracite insert

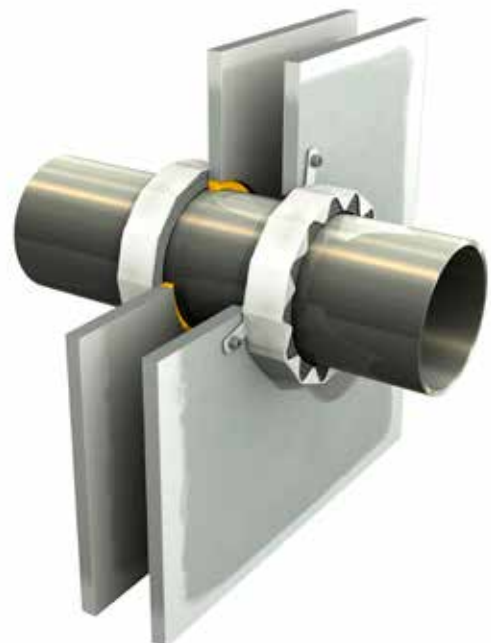

Sikacrete®-630 Fire

Fire resistant load bearing compound



Description

Sikacrete®-630 Fire is a fire resistant gypsum based compound for load bearing penetration seals in floors and walls

Uses

- Vertical penetration seals of combustible and non-combustible services like soil and vent pipes in fire compartment floors and walls
- Can be combined with SikaSeal®-627 Fire Collar, SikaSeal®-628 Fire Wrap or SikaSeal®-629 Fire Wrap

Advantages

- Excellent load bearing properties
- Self supporting in penetrations up to 1.8 x 1.8 m
- Very fast setting, no loss of volume
- Easy to mix, easy to apply
- Up to 2 hours fire resistance

Approvals, Certificates

- ETA acc. EAD-350454-00-1104
- EN 1366-3
- EN 13501-2

- UL EU
- Ecode EC1 Plus
- LEED Attestation

Packaging

- Bag with 20 kg

Colors

- Light grey

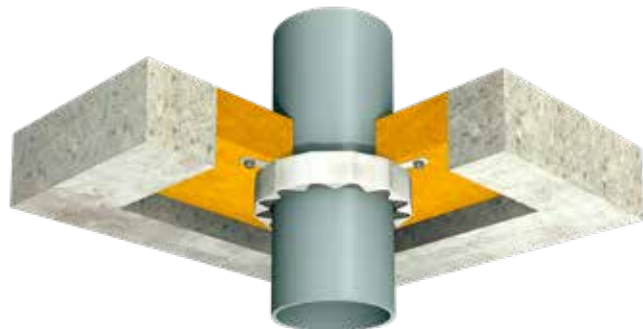

SikaSeal®-628 Fire Wrap

Fire resistant pipe wrap



Description

SikaSeal®-628 Fire Wrap is a fire resistant pipe wrap consisting of one or several layers of intumescent tape sealed in a plastic wrap ready to use for interior and exterior penetration sealing applications. SikaSeal®-628 Fire Wrap is designed to provide a high volume expansion and pressure seal during a fire to combustible pipes that pass through floor and wall service openings.

Uses

- Restores the fire resistance performance of a floor or wall which incorporates service openings containing plastic or composite pipes
- Internal-fit application (installed in the wall/floor) in combination with Sikacryl®-621 Fire
- Can be combined with SikaSeal®-626 Fire Board

Advantages

- Ready to use, pre-cut strips for pipe diameters from 32 to 250 mm

- Highly intumescent - volume expansion 20 times original size
- Invisible installation in walls and floors
- Up to 4 hours fire resistance

Approvals, Certificates

- ETA acc. EAD-350454-00-1104
- EN 1366-3
- EN 13501-2
- UL EU
- Certifire

Packaging

- 25 pieces per box

Colors

- Yellow plastic wrap

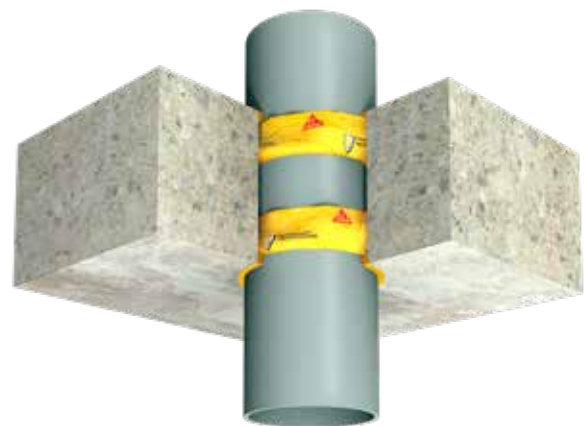

SikaSeal®-629 Fire Wrap

Fire resistant pipe wrap on a roll



Description

SikaSeal®-629 Fire Wrap is a fire resistant pipe wrap on a roll for interior and exterior penetration sealing applications which can be cut to suit varying pipe diameters.

SikaSeal®-629 Fire Wrap is designed to provide a high volume expansion and pressure seal during a fire to combustible pipes that pass through floor and wall service openings.

Uses

- Restores the fire resistance performance of a floor or wall which incorporates service openings containing plastic or composite pipes
- Internal-fit application (installed in the wall/floor) in combination with Sikacryl®-621 Fire
- Can be combined with SikaSeal®-626 Fire Board and Sikacrete®-630 Fire

Advantages

- Pipe diameter range 32 - 250 mm
- Extremely versatile use from a 25 m roll

- Highly intumescent - volume expansion 20 times original size
- Invisible installation in walls and floors
- Up to 4 hours fire resistance

Approvals, Certificates

- ETA acc. EAD-350454-00-1104
- EN 1366-3
- EN 13501-2
- UL EU
- Certifire

Packaging

- Roll with 25 m per box

Color

- Anthracite

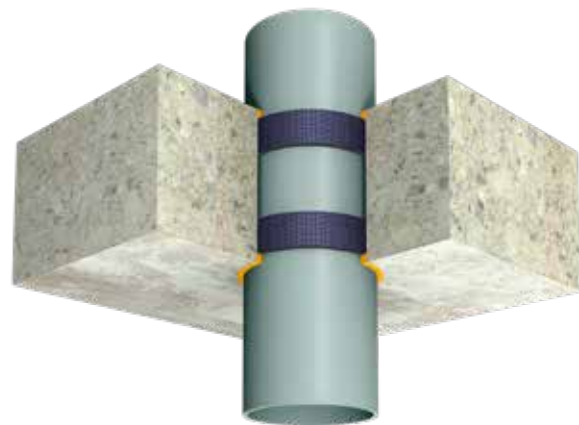

SIKA AS A SOLUTION PROVIDER

Passive fire protection requires more than compartmentalisation in buildings

As shown in the previous pages, Sika provides a full range of passive fire protection products and integrated systems for the building industry. The philosophy behind these and all such fire protection products is to isolate any outbreak of fire at an early stage, and thereby to contain this fire within a so called fire-compartment, which prevents the fire spreading further around the building.

The same approach is followed by Emseal – a Sika company – with their products, which are shown on following pages.

In addition to products used to create fire-compartments,

there are numerous other applications relating to fire resistance and for many of these, Sika also has a high level of expertise and experience, particularly in providing integrated proven system solutions.

On the following pages there is an overview of some of these additional Sika passive fire protection solutions, including examples of some specialist applications in tunnels, and for the fire protection coatings on load bearing building and civil engineering structural components.



SikaCem® Pyrocoat

Fire protection mortar for tunnels and other civil engineering or building structures

In a fire the load bearing elements of a structure can very quickly be exposed to temperatures which are high enough to cause severe damage and significant loss of strength – in the worst case – collapse of the element or even the whole building structure.

In tunnels especially, a fire can cause the temperatures to rise extremely fast because the heat cannot escape, and as a result the resulting vapour pressures in the concrete can lead to explosive spalling and other severe damage. SikaCem® Pyrocoat is a fire resistant, spray applied mortar system which effectively protects concrete and steel elements and structures from such destructive forces.

SikaCem® Pyrocoat has another big advantage in that it is able to provide this high level of protection in thin layers, as proven in fire testing in accordance with the RWS temperature curve up to 1350°C, for example, including prolonged test duration requirements.

The application of SikaCem® Pyrocoat is by traditional thin-layer, wet-spray techniques, generally using SikaCem® Base as a bonding bridge / adhesion promoter without any additional mechanical support or reinforcement. Where necessary the surface can be smoothed after spray application or – for the highest aesthetic requirements – finished with SikaCem®

Finish. In tunnels SikaCem® Pyrocoat combined with Sika-gard® Wallcoat epoxy top coating, provides a protective layer with a mechanical cleaning resistant surface, which is a big advantage for tunnel maintenance.

SikaCem® Pyrocoat is classified as a CS II rendering mortar, suitable for internal and external applications and it can also – using specific application methods – be used in tunnelling.

Advantages

- Suitable for interior and exterior applications
- Low coating thickness
- Minimized material consumption
- High fire resistance
- Mixed product available in bags or silos
- Fast application
- Fast setting time
- High tensile and compression strengths
- Easy to tool and profile
- High load bearing capacity – able to carry insulation or tiling
- Tested acc. RWS temperature curve with prolonged test duration of 150 mins.
- Tested acc. DIN 4102 T4 and EN 13381
- Conforms to EN 998-1, DIN 18550, DIN 4102 T4



EMSEAL Emshield WFR

Fire resistant, watertight vertical wall expansion joint system

EMSEAL's Emshield WFR Fire resistant wall expansion joint is a dual-sided primary seal for repair, retrofit, and new installation in structural expansion joints and construction joints in vertical plane wall and head-of-wall applications. It provides a fire-rated watertight seal that also maintains the wall's thermal and acoustic capacity.

Each piece is custom made to fit in expansion gap widths up to 100 mm. Emshield WFR features water-repellant silicone sealing surfaces adhered to a fire-retardant impregnated foam backing. The symmetrical design allows either side to face out from an exterior or interior wall and maintain a fire resistance up to 4 hours. The facing surfaces are available in many industry-standard colors.

This single-unit expansion joint system installs easily and rapidly. Held in place by the backpressure of the expanding foam, it eliminates any invasive mounting mechanical elements thereby preserving the integrity of the wall. Continuity of seal for fire resistance, water and air seal, thermal barrier and acoustic is achieved with EMSEAL Universal-90 transitions.

Emshield WFR holds an ETA acc. EAD-350141-00-1106 and is CE marked in conformance to EU safety, health and environmental protection requirements. It has been certified up to 4 hours fire resistance in accordance with EN 1366-4 including $\pm 50\%$ joint movement as well as EN 12154 and EN 12155 with no leakage with up to 1200 Pa of pressure. It also meets the requirements of ASTM E1966, ASTM E119 and ASTM E1399 and has been tested in accordance with UL/ULC 2079.



EMSEAL Emshield DFR

Fire resistant, watertight trafficable horizontal deck expansion joint system

EMSEAL's Emshield DFR fire resistant wall expansion joint is a dual-sided primary seal for repair, retrofit, and new installation in structural expansion joints and construction joints in horizontal plane deck and floor applications. It provides a fire resistant watertight seal that also maintains the deck's acoustic and thermal capacity.

Each piece is custom made to fit in expansion gap widths up to 100 mm. Emshield DFR features traffic-grade water-repellant silicone sealing surfaces adhered to a fire-retardant impregnated foam backing. Its fuel-resistant surface supports both vehicular and pedestrian traffic and maintains a fire resistance up to 4 hours.

This single-unit expansion joint installs easily and rapidly. Held in place by the backpressure of the expanding foam, it eliminates any invasive mounting mechanical elements thereby preserving the integrity of the wall.

Continuity of seal, fire resistance, water and air seal, thermal barrier and acoustic achieved with EMSEAL Universal-90 transitions.

Emshield DFR holds an ETA acc. EAD-350141-00-1106 and is CE marked in conformance to EU safety, health and environmental protection requirements. It has been certified up to 4 hours fire rating in accordance with EN 1366-4 testing as well as EN 12154 and EN 12155 with no leakage with up to 1200 Pa of pressure. It also meets the requirements of ASTM E1966, ASTM E119 and ASTM E1399 and has been tested in accordance with UL/ULC 2079.



FIRE PROTECTIVE COATINGS FOR LOAD BEARING STRUCTURES

Fundamentals and surfaces

Fire protective coatings for load bearing structures

With Sika® Unitherm® and Sika® Pyroplast® fire protective coatings, quality and cost-optimised solutions can be realised depending on the required fire-resistance class, the subsequent building codes and the local conditions. Whether steel structures, timber construction elements or concrete – our product portfolio offers reliable building protection according to national and international standards and is used in many important buildings and complexes around the world. Through continuous, market-focused development work, the Sika fire protective products are classified and usable in accordance with the latest European requirements, directives and EN standards.



Function and chemistry of fire protective coatings

Although steel constructions do not burn, very high temperatures can cause them to lose their load-bearing capacity and thus their static stability within a few minutes. The functional principle of fire protective coatings is based on a specific, very complex chemical product composition. Due to the thermal energy of the fire, the bonding agent begins to soften at the surface and is then swelling by the gases produced by an integral foaming agent to form a foam. The originally millimetre-thin coating converts into a centimetre-thick, micro-porous insulating foam that insulates the substrate against heat.

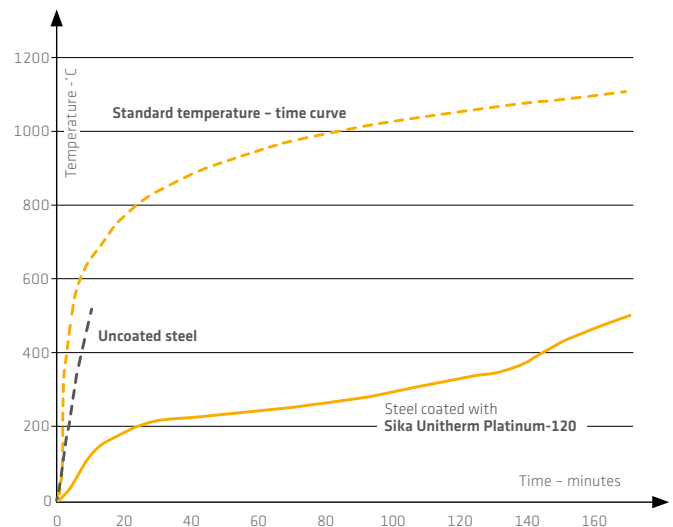

Combination of protection and aesthetics

Circular or rectangular hollow sections are most frequently chosen for their visual appearance. Sika® fire protective coatings allow the unrestricted protection of such components without impairing their visual appearance. In addition, a broad range of decorative finishes will also enhance the appearance of the structure purposefully as a supplementary design element.





Steel

Unlike wooden constructions, steel doesn't burn. But effective fire protective is nonetheless critical here as well. When exposed to extreme heat levels, steel loses its load-bearing capacity and becomes unstable. This puts buildings at risk of collapsing. Fire protective coatings from Sika extend the fire resistance rating of steel structural components to up to 150 minutes, compared with just a few minutes when left unprotected material. A coating thickness with just a few millimeter is sufficient to achieve this. The function, profile, thickness and material of the steel parts are decisive for the required structure and the application of the fire protective coating.



Wood

Wood is a natural building material with a multitude of uses. However, it is flammable and requires effective means of protection especially when used in public buildings. Sika® Pyroplast® Wood fire protective systems can inhibit or delay inflammation on the surface and the spread of flame. The sustainable fire protective coatings combine highest protection with aesthetic advantages. Although the coating is so thin it does not conceal the natural beauty of the wood.



Concrete

Like steel, concrete does not burn and belongs to the Class-A building materials. However, the high input of heat resulting from the fire leads to a reduction in the strength and rigidity of the concrete. That causes explosive spalling also for high strength concrete mixtures up to the collapses of the entire construction. Fire protection for concrete is used where a fire protection retrofit is necessary in a building due to a change of use or inventory.

FIRE PROTECTIVE COATINGS FOR LOAD BEARING STRUCTURES

Advantages of intumescent coatings



Only a few millimeters thick and applied in line with the profile, emphasizes the filigree nature of the structural steel design



Can be applied in all environments, even those with particularly high requirements such as swimming baths and power stations



Due to their insignificant weight, the structural load calculation does not change



Maintenance-free over their long service lives





Can be applied on site or in the workshop



Fast application rate can assist construction programs



The fast-drying, impact-resistant coatings combine resistance to corrosion and fire with long periods of fire resistance of more than 2 hours



For the coating of interior areas there are especially low-emission systems that even comply with the high demands required for sustainability certification (MesseNürnberg - Heiko Stahl)



FIRE PROTECTIVE SYSTEMS FOR STEEL STRUCTURES

Solvent-free fire protective coatings – the platinum-technology

Platinum is Sika's innovative technology to protect steel structures from corrosion and fire. The Platinum range is a total solid, environmentally-conscious technology for a sustainable future, customized to suit the widest range of needs for a fast and cost effective application. A very damage resistant and flexible coating which incorporates additional anti-corrosion protection to withstand the impact of the most aggressive environmental factors.

The Platinum-Technology emphasizes the contemporary design of steel structure and delivers answers the most common and world leading green building schemes. Keep one step ahead of conventional solutions!

Information at a glance

- Solvent-free, 2-pack intumescent coatings for structural steel
- Increasing fire resistance duration of beams, pillars and frame members in the interior and the exterior of buildings
- When heated it forms a thermally insulating layer which increases the fire resistance duration of steel components (R30 to R120)

Advantages

- Solvent-free, 100 % solids
- Low odour and zero flash risk
- Halogen-free
- Complies with Indoor Air Comfort Gold® limit values by EUROFINs, even as coating system
- Easy application with single-leg spray equipment
- Can be applied in 1-coat for up to 4 mm dft (dry film thickness), no additional reinforcement required at any time
- Application directly on blast cleaned steel surfaces
- Rapid cure - next day handling and transport
- Very tough - minimal handling damage and touch-up costs
- Highly resistant to mechanical impact and damage in service
- Suitable for small sections and complex steel sections
- Very good cosmetic appearance
- Durable for a long service life
- Expected life cycle > 25 years
- Meets Type X classification (i.e. exterior conditions), no primer and top coat needed
- Excellent corrosion protection properties according to ISO 12944, corrosivity class C5 (as coating system)





FIRE PROTECTIVE SYSTEMS FOR STEEL STRUCTURES

Solvent-based fire protective coatings – Sika® Unitherm® Steel S

Solvent-based coating systems are used for steel structures in the *interior and exterior of buildings that are exposed to the effects of the weather, industrial atmospheres and high humidity (including the maritime environment).

They emphasise design-oriented shapes and contribute with their low coating thicknesses to the decorative accentuation and design. These proven systems thus emphasise both the aesthetics and the protective function, without visually and spatially limiting structural design.

Proven all-round systems with a longevity of over 30 years have been developed in the long Sika tradition. In conjunction with the specific primers, very good corrosion protection properties are achieved, depending on the system. The application, which can also be done off-site, is user-friendly – through the use of usual equipment.

Information at a glance

- Solvent-based, 1-pack intumescent coatings for structural steel
- Increasing fire resistance duration of beams, pillars and frame members in the *interior and the exterior of buildings

- When heated it forms a thermally insulating layer which increases the fire resistance duration of steel components (R30 to R90)

* For interior use on structural steel members like columns, girders and framework as long as there is no demand for national emission schemes, i.e. German AgBB, etc.

Advantages

- Applicable on steel constructions exposed to weathering
- CE-classified according ETAG 018 part 2, the system meets Type X classification (i.e. exterior conditions)
- Preserves the appearance of a steel construction
- Applicable to filigree and complex steel building elements
- VOC < 350 g/l
- Simple application, does not increase static load
- Sprayable with all medium size airless spray equipment, electrical or pneumatically
- The application can be done off-site
- Individual coloration possible with corresponding topcoat, various colour shades in RAL, others available



FIRE PROTECTIVE SYSTEMS FOR STEEL STRUCTURES

Water-based fire protective coatings – Sika® Unitherm® Steel W

Water-based, halogen and aromatic solvent-free coatings are used to protect steel structures situated inside the building. They are ideal suitable for use in eco-constructions, to keep a healthy interior environment with a minimum of pollutants whilst application. With a new binder technology, our latest generation covers the fire resistance periods from 30 to 90 minutes. Fewer work steps with high coating thicknesses but nevertheless attractive surface quality characterise this new line of development. A VOC of 1 g/l means only the minutest of emissions, whereby the aspect of sustainability is particularly highlighted. Fast drying behaviour in conjunction with the aforementioned features makes this system enormously efficient and economical.

Information at a glance

- Water-based, 1-pack intumescent coatings for interior structural steel
- Increasing fire resistance duration of beams, pillars and frame members in the interior buildings
- When heated it forms a thermally insulating layer which

increases the fire resistance duration of steel components (R30 to R90)

Advantages

- Ecological and efficient water based coating
- Fast drying
- Free of halogens and aromatic solvents
- Complies with German AgBB and French VOC (A+), even as coating system
- Meets Type Z1 classification (i.e. internal conditions includes temperatures till + 5°C and high humidity) without topcoat
- Preserves the appearance of a steel construction
- Applicable to filigree and complex steel building elements
- Simple application, does not increase static load
- Sprayable with all medium size airless spray equipment, electrical or pneumatically
- The application can be done on-site
- Individual coloration possible with corresponding topcoat, various colour shades in RAL, DB, others available



FIRE PROTECTIVE SYSTEMS FOR WOOD

Water-based fire protective coatings – Sika® Pyroplast® Wood

Sika® Pyroplast® are fire protective coatings which are simply painted or sprayed on to the wood either in a transparent or pigmented form. Although the coatings are so thin they do not conceal the natural beauty of the wood they nevertheless have exactly the properties to prevent the wood from burning too soon and also inhibit the rapid spread of flame. So the load-bearing function of the overall structure is maintained longer. On exposure to heat, the coatings are converted into a centimetre-thick layer of foam which is heat-insulating and thus prevents the wood from ignition. Furthermore, this micro-porous carbon foam acts as an oxygen barrier on the flammable surface of the wood and prevents flames from spreading even over large areas of wooden surfaces.

Information at a glance

- Water-based, 1-pack intumescent coatings for interior use
- Tested to provide spread-of-flame protection and delays the

- inflammation of natural wood and wood derivatives
- Forms a carbon char under the effect of heat
- Insulates against heat, checks fire, prevents propagation of fire and spread of flame and diminishes fluegas temperatures

Advantages

- Ecological water based coating system
- Free of halogens and aromatic solvents
- Complies with German AgBB, French VOC (A+) and Scandinavian M1 as coating system
- Low material consumption
- Simple application
- No additional statical load of coating
- Emphasizes the interior design of timber structures and provides an attractive option to architects, builders and end-users
- Individual coloration possible



FIRE PROTECTIVE SYSTEMS FOR CONCRETE

Water-based fire protective coatings – Sika® Unitherm® Concrete W

A major factor in the service life of a building is the influence of the thermal conductivity on the load-bearing capacity of the building material. This is significantly lower for concrete than in the case of pure steel constructions.

Years ago it was still believed that concrete is resistant to every kind of damaging effect. But: concrete is vulnerable! For example, corrosion due to carbonated concrete or corrosion due to chloride contamination. This results in the following requirements for the fire protection of concrete: the fire resistance duration must be increased in case of a change of use, the coverage of reinforcement must be improved and corrosion damage through external contamination must be prevented.

Information at a glance

- Water-based, 1-pack intumescent coatings for interior use on concrete, masonry and brickwork to improve the fire resistance

- Forms an insulating carbon char foam under the effect of heat or fire and protects the concrete substrate against heat and fire
- Prohibits the spalling of concrete structures and significantly delays the build up of steel reinforcements

Advantages

- Ecological and efficient water based coating
- Low material consumption
- Simple and easy application
- Free of halogens and aromatic solvents, VOC < 1 g/l
- Meets CO2 SD (Class C1) > 50m without any additional coating
- Direct application on concrete. No need of primer or scrim
- Third party approved repair mortars of the Sika MonoTop® range
- Individual coloration possible by use of topcoat



NOTES

GLOBAL BUT LOCAL PARTNERSHIP

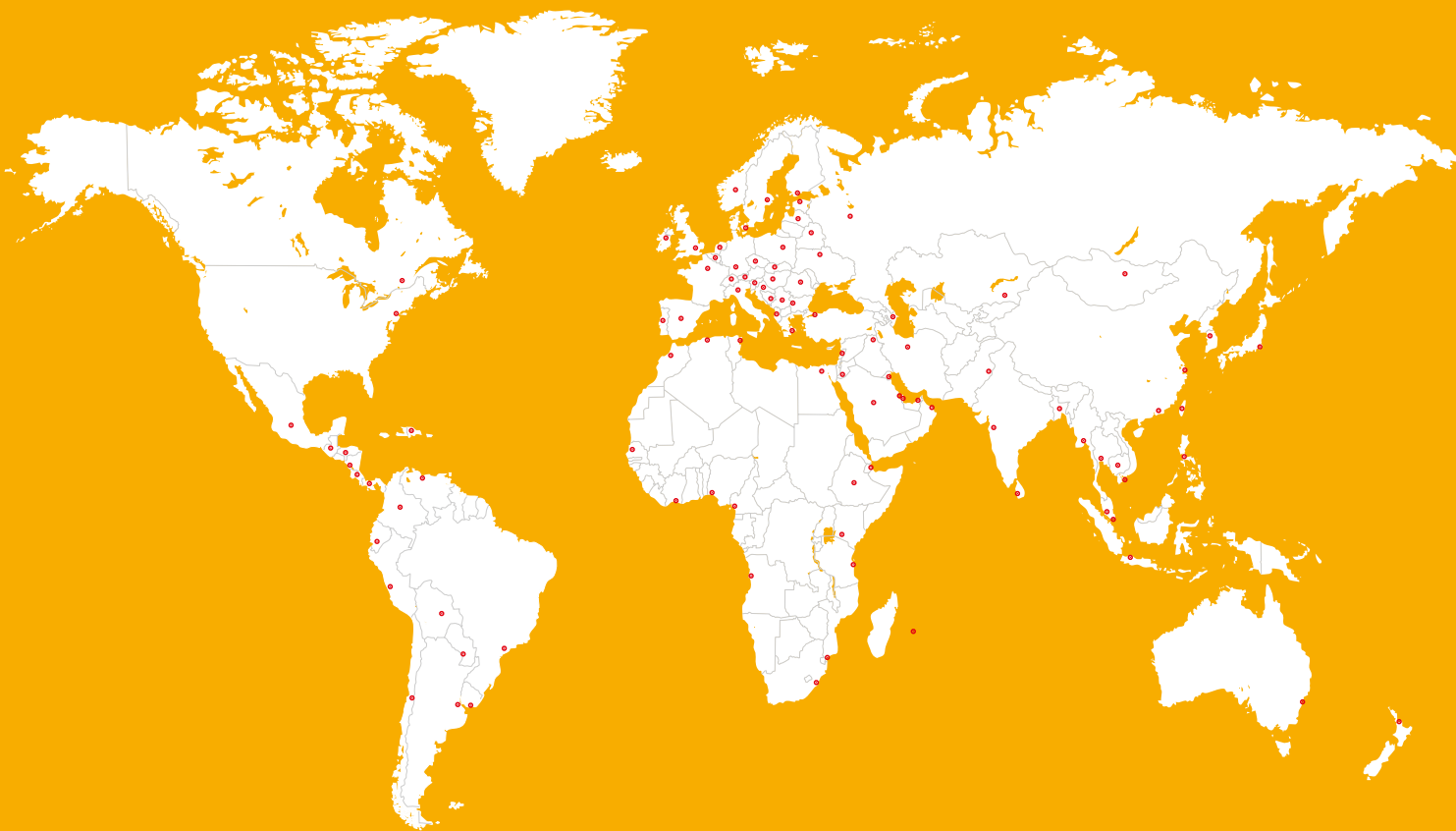

FOR MORE SEALING & BONDING INFORMATION:

WE ARE SIKA

Sika is a specialty chemicals company with a leading position in the development and production of systems and products for bonding, sealing, damping, reinforcing and protecting in the building sector and the motor vehicle industry. Sika's product lines feature concrete admixtures, mortars, sealants and adhesives, structural strengthening systems, flooring as well as roofing and waterproofing systems.

Our most current General Sales Conditions shall apply. Please consult the most current local Product Data Sheet prior to any use.



SIKA SERVICES AG
Tueffenwies 16
CH-8048 Zurich
Switzerland

Contact
Phone +41 58 436 40 40
Fax +41 58 436 41 50
www.sika.com

BUILDING TRUST

